

Switching

- Packets must be sent from host to host across a directed network.
- Three types of switching are employed.
 - Circuit Switching
 - Message Switching
 - Packet Switching

100

Circuit Switching

- Like old fashioned terrestrial telephone system.
- Try to form dedicated physical path from source to destination.
- Path remains dedicated until session is terminated.
- Not typical operation of bursty comms.

101

Circuit Switching

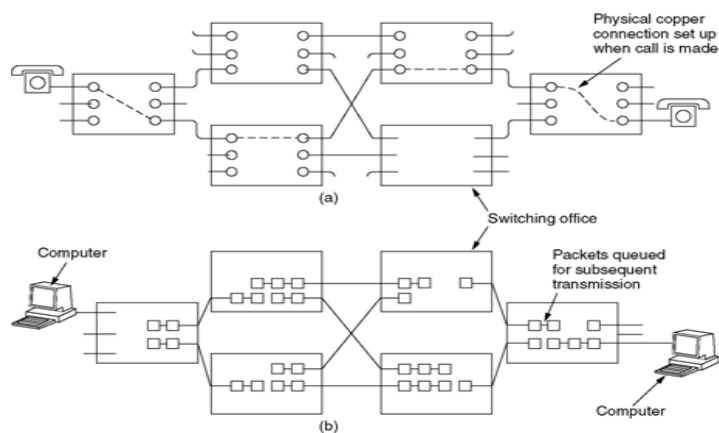

- (a) Circuit switching.
- (b) Packet switching.

102

Message Switching

- No physical path established.
- Large bursts of data transmitted from sender to receiver.
- Each burst stored and forwarded from host to host throughout network.
- No limit to burst size, may encounter memory\buffering and link availability problems.

103

Message Switching

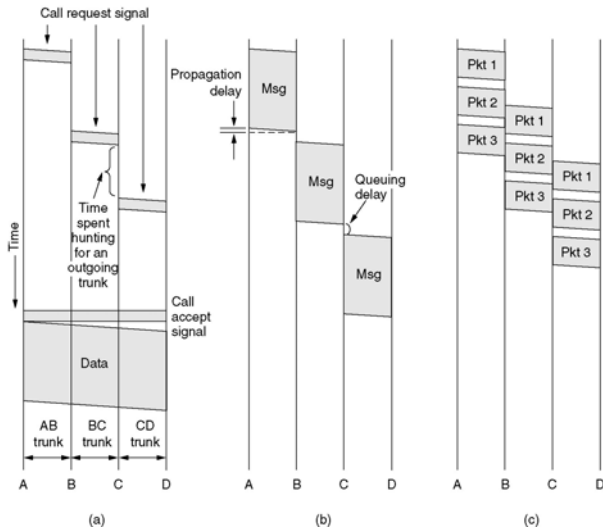

(a) Circuit switching (b) Message switching (c) ¹⁰⁴

Packet Switching

- Upper limit set on size of blocks to be transmitted.
- Ideal for bursty computer communications.
- May utilise pipelining to improve throughput.
- Large packet size will emulate message switching, small emulates circuit switching.

105

Packet Switching

| Item | Circuit-switched | Packet-switched |
|------------------------------------|------------------|-----------------|
| Call setup | Required | Not needed |
| Dedicated physical path | Yes | No |
| Each packet follows the same route | Yes | No |
| Packets arrive in order | Yes | No |
| Is a switch crash fatal | Yes | No |
| Bandwidth available | Fixed | Dynamic |
| When can congestion occur | At setup time | On every packet |
| Potentially wasted bandwidth | Yes | No |
| Store-and-forward transmission | No | Yes |
| Transparency | Yes | No |
| Charging | Per minute | Per packet |

A comparison of circuit switched and packet-switched networks